

# SM 414 PROFI

## Technical Data (dimensions in mm)

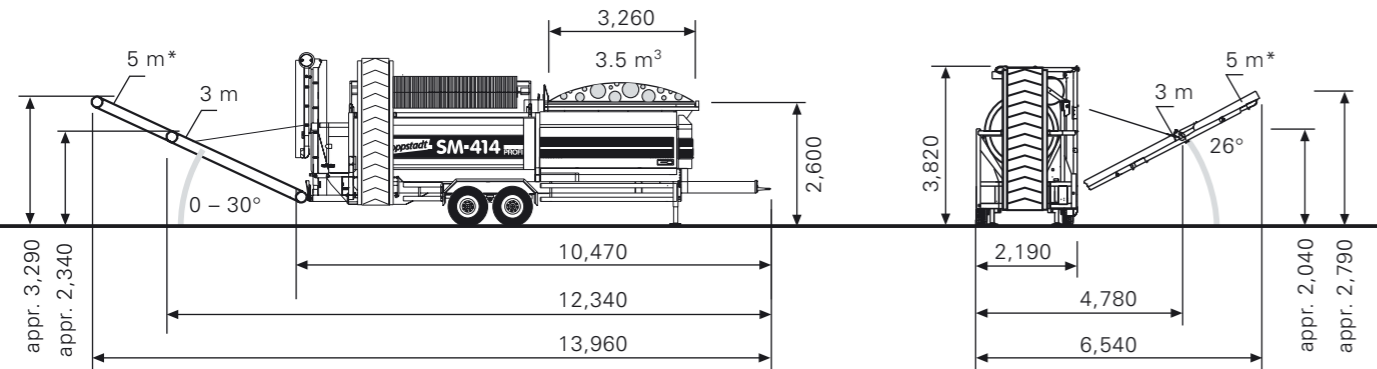

<b>Maximum total weight</b>	10,500 kg	
<b>Description</b>	Mobile trommel screen, mounted on a central axle trailer for 80 km/h speed according to StVZO, with ABS	
<b>Feature</b>	2 screening fractions 3. fraction by stonegrid	
<b>Drive</b>	Diesel engine	
<b>Type</b>	Caterpillar 3024 C (option: electric motor)	
<b>Power</b>	28 kW (38 hp) at rated speed 2,000 rpm	
<b>Max. Torque</b>	135 Nm	
<b>Exhaust level</b>	EUROMOT 2	
<b>Fuel tank</b>	100 l	
<b>Trommel*</b>		
<b>Diametre</b>	1,400 mm	
<b>Length</b>	4,200 mm	
<b>Mesh size</b>	at choice 5-100 mm	
<b>Mesh form</b>	at choice (square holes, staggered squares, round holes)	
<b>Thickness</b>	at choice 5-10 mm	
<b>Speed</b>	0-23 rpm	
<b>Conveyors</b>	rear	side
<b>Length</b>	3,000 mm (opt. 5 m*)	3,000 mm (opt. 5 m*)
<b>Width</b>	600 mm	600 mm
<b>Belt speed</b>	0.9 m/s	2.1 m/s
<b>Options</b>	Stonegrid, remote control, longer conveyors (5 m), additional hydraulic connection, start-stop sorting, rear belt speed continuously adjustable, magnetic drums, replaceable screening elements etc.	



**Doppstadt**

**SM 414 PROFI**  
Screen

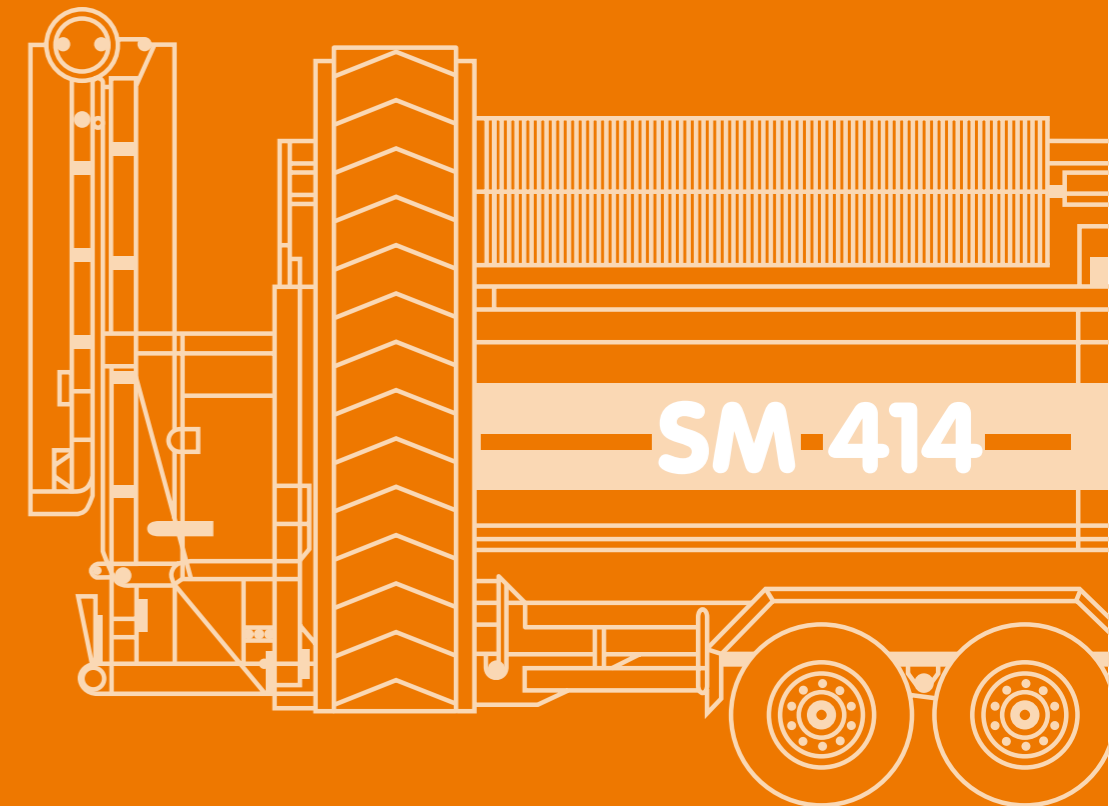

**Doppstadt Calbe GmbH**  
Barbyer Chaussee 3  
39240 Calbe/Saale, Germany  
phone: (+49) 3 92 91 / 55 - 270  
fax: (+49) 3 92 91 / 55 - 358  
info@doppstadt.com  
www.doppstadt.com

May 2005, specifications subject to technical alterations.  
The specifications are approximate, illustrations and descriptions might include options that are not part of the standard equipment.

**Doppstadt**

**Doppstadt**



>>> **The compact screen...**

...is the getting in on the powerful Doppstadt Profi series of screens. The screening of most difficult materials can be carried out without problems by the rotating trommel. The patented, load-sensing material feed enables an optimum utilization of the large screening surface (15,9 m<sup>2</sup>). Thanks to the modular principle, the basic machine can easily be equipped with a wide choice of options to meet your special requirements. All the Doppstadt machines stand out for their operator convenience and mobility.

- >>> 1 Maintenance-friendly thanks to large protection doors, slewable motor unit and central lubrication.
- >>> 2/4 The roller-bearing of the trommel and the direct drive by a robust pinion ensure operational safety and easy trommel exchange.
- >>> 3 The hydraulically hinged stonegrid\* enables the separation of a 3rd. fraction.
- >>> 5 Short set-up operation time thanks to the hydraulically foldable discharge conveyors (<10 min).
- >>> 6 Self-cleaning of the trommel by turning, hydraulically controlled brush.
- >>> 7 Mechanic level regulation for optimum passage of the material and stability.
- >>> 8 Easy one-man operation, the machine can be moved by slip-on coupling.

\*) option



**Screening of soil, compost, bark mulch, waste wood, light building rubble...**

**Possibility of optimum combination with other DOPPSTADT-products, e.g. shredders and windsifters.**

