

SM 518 PROFI

Technical Data (dimensions in mm)

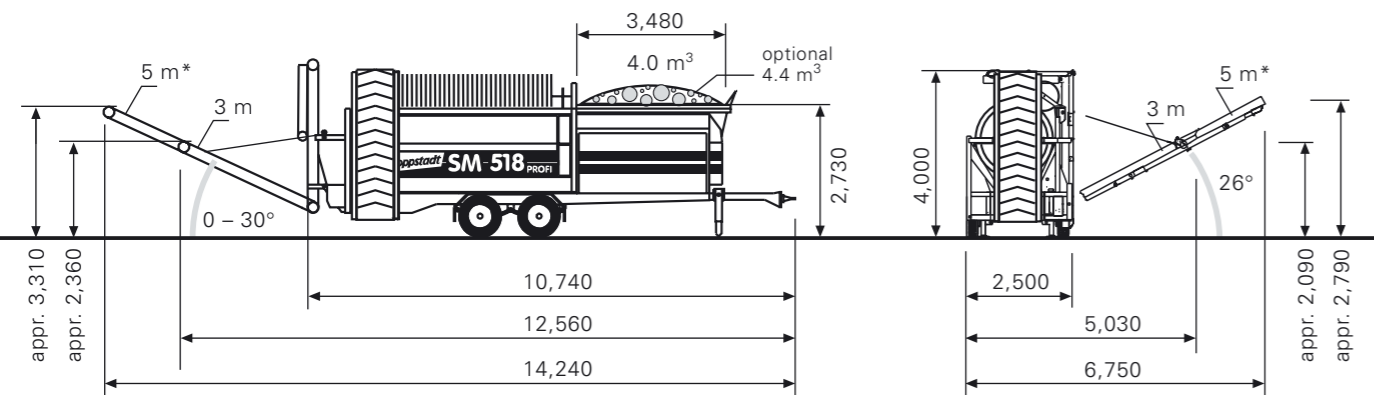

Permissible total weight	13,500 kg	(option: 15,000 kg)
Description	Mobile trommel screen, mounted on a central axle trailer for 80 km/h speed according to road traffic regulations, with ABS	
Feature	2 screening fractions 3. fraction by stonegrid* or vibrating screen*	
Drive	Diesel engine	
Type	Caterpillar 3044 C (option: DaimlerChrysler OM 904 LA; electric motor)	
Power	44 kW / 2,100 rpm	
Max. Torque	200 Nm	
Emission standard	EUROMOT 2	
Fuel tank	300 l	
Trommel*	(option: basic trommel with replaceable screening elements)	
Diameter	1,800 mm	
Length	4,700 mm	
Mesh size	at choice 5-100 mm	
Mesh form	at choice (square holes, staggered squares, round holes)	
Thickness	at choice 4-12 mm	
Speed	0 - 22 rpm	
Conveyors	rear	side
Length	3,000 mm (opt. 5 m*)	3,000 mm (opt. 5 m*)
Width	800 mm	800 mm
Belt speed	1.5 m/s	3.1 m/s
Options	Stonegrid or vibrating screen, remote control, larger hopper, longer conveyors (5 m), additional hydraulic connection, start-stop sorting, rear belt speed continuously adjustable, magnetic head pulley / overband magnet, replaceable screening elements, hydraulic level regulation, crawler tracks (katte) etc.	

Doppstadt Calbe GmbH
 Barbyer Chaussee 3
 39240 Calbe/Saale, Germany
 phone: (+49) 3 92 91 / 55 - 270
 fax: (+49) 3 92 91 / 55 - 358
 info@doppstadt.com
 www.doppstadt.com

September 2004, specifications subject to technical alterations.
 The specifications are approximate, illustrations and descriptions might include options that are not part of the standard equipment.



Doppstadt

SM 518 PROFI
 Screen

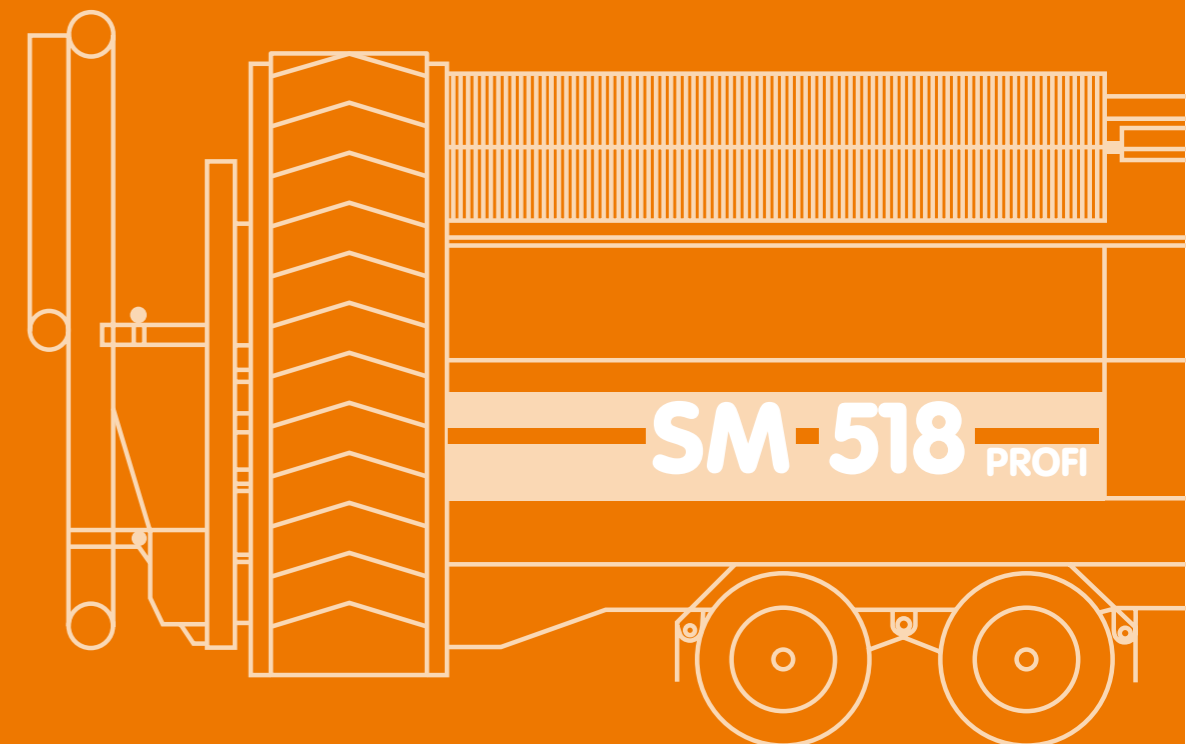

Doppstadt

Doppstadt



1

2

3

>> Stone

>> Organic waste, compost...

>> Stone, soil, rubble, hardcore...

>> Compost...

>>> **One of the best-selling screens...**

...thanks to the outstanding cost-effectiveness. The screening of most difficult materials can be carried out without problems by the rotating trommel. The patented, load-sensing material feed enables an optimum utilization of the large screening surface (22.5 m²). Thanks to the modular principle, the basic machine can easily be equipped with a wide choice of options to meet your special requirements.



Screening of soil, compost, bark mulch, waste wood, mixed construction waste, light building rubble...

Possibility of optimum combination with other DOPPSTADT-products, e.g. shredders, windsifters or sorting stations.

- >>> 1 Maintenance-friendly thanks to large protection doors, slewable motor unit and central lubrication.
- >>> 2/4 The direct drive by a robust pinion ensures operational safety and easy trommel drum exchange.
- >>> 3 The hydraulically hinged Grid* or vibrating grid enables the separation of a third fraction of material.

- >>> 5 Short set-up operation time thanks to the hydraulically foldable discharge conveyors (<10 min).
- >>> 6 Self-cleaning of the trommel by turning, hydraulically controlled brush.
- >>> 7 Machine can be easily moved with one person using wheel loader and special attachment as shown.
- >>> 8 A solid drum with holes can be used (2) or a drum with replaceable screen/mesh panels (8) according to the material type.

*) option

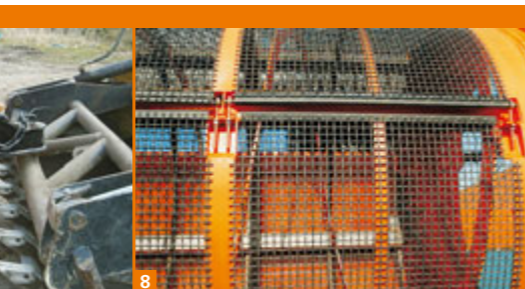
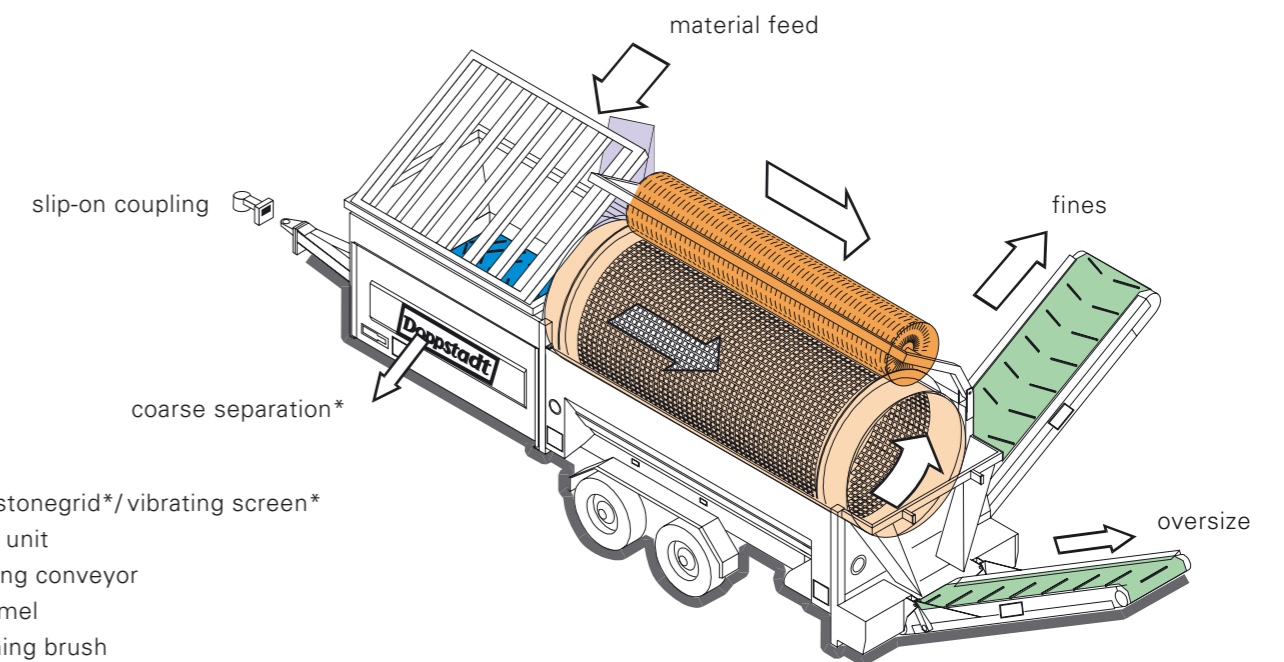

4

5

6

7

8